



- NO and NC in one casing**
- Separate adjustable temperatures**
- High switching capacity**
- Terminals easily accessible**
- Clip fixing**

Two thermostats in one casing:
 Thermostat (contact breaker, normally closed) for regulating heaters.
 Thermostat (contact maker, normally open) for regulating filter fans and heat exchangers or switching signal devices when temperature limit has been exceeded.

Heaters and cooling equipment can be switched independently from each other with a temperature offset as opposed to the usual change-over contacts.



Technical Data

Switch temperature difference	7K (± 4K tolerance)
Sensor element	thermostatic bimetal
Contact type	snap-action contact
Contact resistance	< 10mOhm
Service life	> 100,000 cycles
Max. Switching capacity	250VAC, 10 (2) A 120VAC, 15 (2) A DC 30W
EMC	acc. to EN 55014-1-2, EN 61000-3-2, EN 61000-3-3
Connection	4-pole terminal for 2.5mm ² , clamping torque 0.8Nm
Mounting	clip for 35mm DIN rail, EN50022
Casing	plastic according to UL94 V-0, light grey
Dimensions	67 x 50 x 46mm
Weight	approx. 90g
Fitting position	variable
Operating/Storage temperature	-20 to +80 °C (-4 to +176 °F) / -45 to +80 °C (-49 to +176 °F)
Protection type	IP20
Approvals	UL File No. E164102

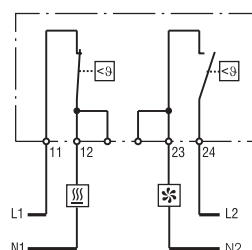
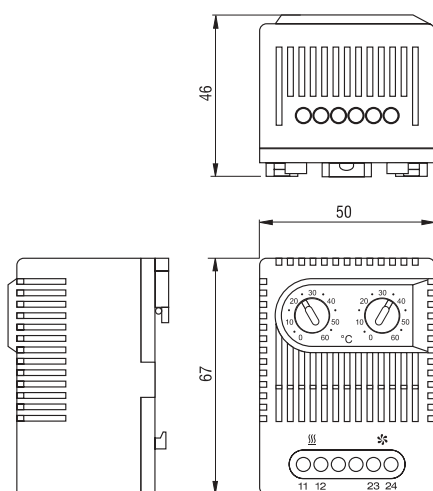

Load 1: Heater
 Load 2: Filter fan, Cooling equipment, Signal device

Art. No.	Setting Range		Setting Range	
	contact breaker, normally closed	0 to +60°C	contact maker, normally open	0 to +60°C
01172.0-00	contact breaker, normally closed	+32 to +140°F	contact maker, normally open	+32 to +140°F
01175.0-00	contact breaker, normally closed	-10 to +50°C	contact maker, normally open	+20 to +80°C
01175.0-01	contact breaker, normally closed	+14 to +122°F	contact maker, normally open	+68 to +176°F
01176.0-00*	contact maker, normally open	0 to +60°C	contact maker, normally open	0 to +60°C
01176.0-01*	contact maker, normally open	+32 to +140°F	contact maker, normally open	+32 to +140°F

*For regulating heat exchangers and fans (e.g. LE 019) and as an alarm contact for monitoring the interior temperature of electronic enclosures.

Electronic Relay SM 010 (24VDC + 48VDC)



- **High DC switching capacity**
- **Variety of applications**
- **Compact design**
- **Simple connection**
- **Clip fixing**

Electronic relay for switching DC appliances with high switching capacity. A separate conventional switch contact is used as controller (e.g. temperature regulator, humidity regulator). The electronic relay is available in 24VDC and 48VDC versions.

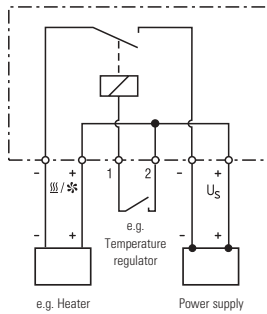
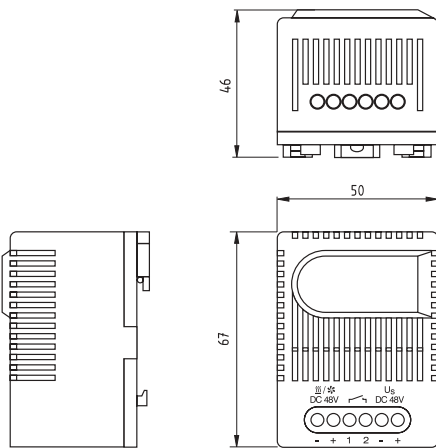

Technical Data

Contact type	contact maker, normally open (Relay/MOSFET)
Contact resistance	< 10mOhm
Service life	> 100,000 cycles
EMC	acc. to EN 55014-1-2, EN 61000-3-2, EN 61000-3-3
Connection	6-pole terminal for 2.5mm ² , clamping torque 0.8Nm
Mounting	clip for 35mm DIN rail, EN50022
Casing	plastic according to UL94 V-0, light grey
Dimensions	67 x 50 x 46mm
Weight	approx. 85g
Fitting position	variable
Operating/Storage temperature	-45 to +70°C (-49 to +158°F)
Protection type	IP20
Approvals	VDE and UL intended

Load, e.g. heater, cooling device with temperature cut-out

SM 010 Electronic relay

Control contact, e.g. temperature, humidity or pressure regulator

Load, e.g. heater, cooling device without temperature cut-out

SM 010 Electronic relay

Control contact, e.g. temperature, humidity or pressure regulator

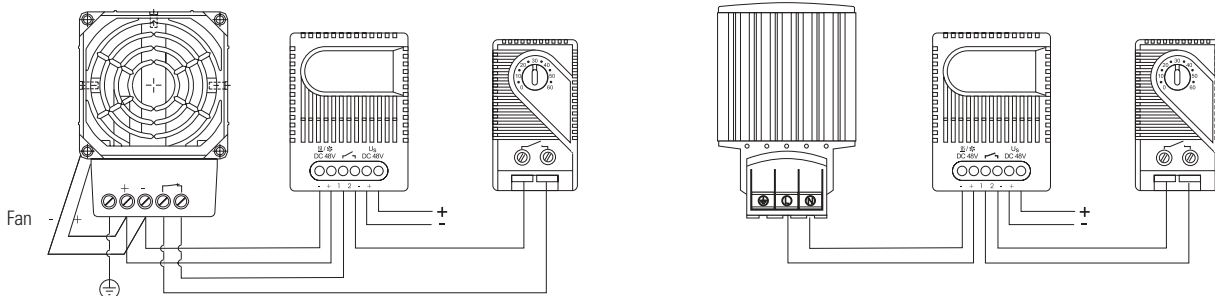

Art. No.	Operating voltage	Max. Switching capacity
01001.0-00	24VDC (20-28VDC)	28VDC 16A
01000.0-00	48VDC (38-56VDC)	56VDC 16A

Slimline Lamp SL 025 Series with on/off switch

Photo: Slimline lamp with on/off switch, with integrated electric socket (Germany), Art. No. 02520.0-00



- Slim casing
- Electronic ballast
- Lamp without/with electrical socket (choice of sockets)
- Magnet fixing (option)
- Energy saving lamp
- On/Off switch

The flat slimline lamp SL 025 is suitable for all types of panels and enclosures, especially where space is at a premium. The lamp can be mounted on its narrow or broad surface using screws. It is also available with a magnet which allows it to be fitted quickly in any position in a steel enclosure. Both versions are available with an integrated electrical socket enabling the use of additional appliances.



Technical Data

Power consumption	11W (equals 75W light bulb)
Luminosity	900Lm
Lamp type	energy saving lamp, 2G7 socket
Service life	10,000h
Switch	on/off light switch
Connection	terminal 2.5mm ² with cable clamp, torque 0.8Nm max.
Mounting	screw fixing, M5, 300mm centers magnet fixing (optional)
Casing	plastic according to UL94 V-0, light grey
Dimensions	345 x 91 x 40mm
Fitting position	narrow surface/broad surface
Operating / Storage temperature	-20 to +50°C (-4 to +122°F) / -45 to +70°C (-49 to +158°F)
Protection type	IP20
Note	The slimline lamp SL 025 is also available with a 19" front panel 24VDC to 48VDC on request

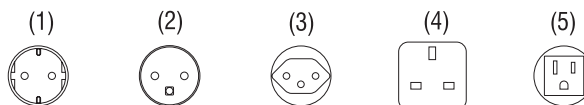
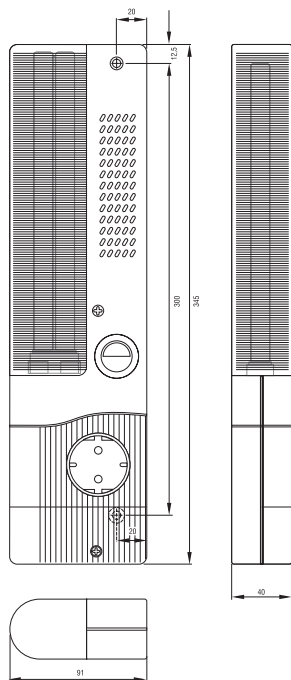

Art. No.	Model	Operating Voltage	Socket	Nominal Current	Weight (approx.)	Protection class	Approvals
02520.0-00	without magnet	230VAC, 50/60Hz	Germany/Russia (1)	16.0A	0.4kg	I (earthed)	VDE
02520.1-01	with magnet	230VAC, 50/60Hz	Germany/Russia (1)	16.0A	0.5kg	I (earthed)	VDE
02521.0-00	without magnet	230VAC, 50/60Hz	F/PL/CZ/SK (2)	16.0A	0.4kg	I (earthed)	VDE
02521.1-04	with magnet	230VAC, 50/60Hz	F/PL/CZ/SK (2)	16.0A	0.5kg	I (earthed)	VDE
02522.0-00	without magnet	230VAC, 50/60Hz	Switzerland (3)	10.0A	0.4kg	I (earthed)	VDE
02522.1-01	with magnet	230VAC, 50/60Hz	Switzerland (3)	10.0A	0.5kg	I (earthed)	VDE
02523.0-00	without magnet	230VAC, 50/60Hz	UK/Ireland (4)	13.0A	0.4kg	I (earthed)	VDE
02523.1-05	with magnet	230VAC, 50/60Hz	UK/Ireland (4)	13.0A	0.5kg	I (earthed)	VDE
02524.0-01	without magnet	120VAC, 50/60Hz	USA/Canada (5)	15.0A	0.4kg	I (earthed)	UL File No. E234324
02524.1-05	with magnet	120VAC, 50/60Hz	USA/Canada (5)	15.0A	0.5kg	I (earthed)	UL File No. E234324
02527.0-00	without magnet	230VAC, 50/60Hz	none	-	0.4kg	II (double insulated)	VDE + UL File No. E234324
02527.1-14	with magnet	230VAC, 50/60Hz	none	-	0.5kg	II (double insulated)	VDE
02527.0-10	without magnet	120VAC, 50/60Hz	none	-	0.4kg	II (double insulated)	UL File No. E234324
02527.1-11	with magnet	120VAC, 50/60Hz	none	-	0.5kg	II (double insulated)	UL File No. E234324

Slimline Lamp SL 025 Series with movement sensor

Photo: Slimline lamp with movement sensor and with integrated electric socket (Germany), Art. No. 02520.0-03

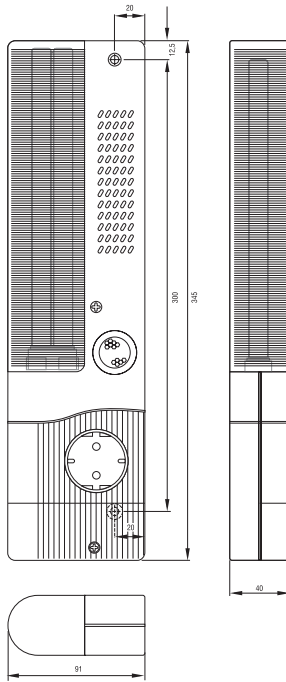

- Slim casing**
- Electronic ballast**
- Lamp without/with electrical socket (choice of sockets)**
- Magnet fixing (option)**
- Energy saving lamp**
- Automatic switching**

The flat slimline lamp SL 025 with movement sensor is suitable for all types of panels and enclosures, especially where space is at a premium. The lamp can be mounted on its narrow or broad surface using screws. It is also available with a magnet which allows it to be fitted quickly in any position in a steel enclosure. Both versions are available with an integrated electrical socket enabling the use of additional appliances. The movement sensor substitutes a door contact switch.



Technical Data

Power consumption	11W (equals 75W light bulb)
Luminosity	900Lm
Lamp type	energy saving lamp, 2G7 socket
Service life	10,000h
Switch	PIR movement sensor, approx. 6min. fixed switch-on duration
Connection	terminal 2.5mm ² with cable clamp, torque 0.8Nm max.
Mounting	screw fixing, M5, 300mm centers magnet fixing (optional)
Casing	plastic according to UL94 V-0, light grey
Dimensions	345 x 91 x 40mm
Fitting position	narrow surface/broad surface
Operating / Storage temperature	-20 to +50°C (-4 to +122°F) / -45 to +70°C (-49 to +158°F)
Protection type	IP20
Note	The slimline lamp SL 025 is also available with a 19" front panel 24VDC to 48VDC on request

The PIR movement sensor switches the lighting on when the enclosure door is opened. The switch-on time is reset with every further registered movement. The movement sensor does not react to movement on the other side of glass and so can be used in enclosures with glass doors.

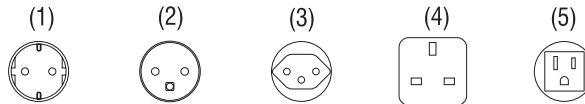

Art. No.	Model	Operating Voltage	Socket	Nominal Current	Weight (approx.)	Protection class	Approvals
02520.0-03	without magnet	230VAC, 50/60Hz	Germany/Russia (1)	16.0A	0.4kg	I (earthed)	VDE
02520.1-04	with magnet	230VAC, 50/60Hz	Germany/Russia (1)	16.0A	0.5kg	I (earthed)	VDE
02521.0-03	without magnet	230VAC, 50/60Hz	F/PL/CZ/SK (2)	16.0A	0.4kg	I (earthed)	VDE
02521.1-05	with magnet	230VAC, 50/60Hz	F/PL/CZ/SK (2)	16.0A	0.5kg	I (earthed)	VDE
02522.0-03	without magnet	230VAC, 50/60Hz	Switzerland (3)	10.0A	0.4kg	I (earthed)	VDE
02522.1-04	with magnet	230VAC, 50/60Hz	Switzerland (3)	10.0A	0.5kg	I (earthed)	VDE
02523.0-03	without magnet	230VAC, 50/60Hz	UK/Ireland (4)	13.0A	0.4kg	I (earthed)	VDE
02523.1-04	with magnet	230VAC, 50/60Hz	UK/Ireland (4)	13.0A	0.5kg	I (earthed)	VDE
02524.0-04	without magnet	120VAC, 50/60Hz	USA/Canada (5)	15.0A	0.4kg	I (earthed)	UL File No. E234324
02524.1-06	with magnet	120VAC, 50/60Hz	USA/Canada (5)	15.0A	0.5kg	I (earthed)	UL File No. E234324
02527.0-04	without magnet	230VAC, 50/60Hz	none	-	0.4kg	II (double insulated)	VDE + UL File No. E234324
02527.1-15	with magnet	230VAC, 50/60Hz	none	-	0.5kg	II (double insulated)	VDE
02527.0-12	without magnet	120VAC, 50/60Hz	none	-	0.4kg	II (double insulated)	UL File No. E234324
02527.1-17	with magnet	120VAC, 50/60Hz	none	-	0.5kg	II (double insulated)	UL File No. E234324

Hazardous area Thermostat REx 011 Series 15°C, 25°C



Compact design

Set temperature

High switching capacity

Compact small mechanical thermostat for temperature regulation and monitoring of heaters, for example in transmitter cabinets, control panels and measuring equipment which are deployed in areas with explosion hazard. The special switch construction enables high response accuracy, small switch temperature difference and a very long service life. High switching performance allows direct control of the heaters.



Technical Data

Explosion proof according to EN	LCIE (Laboratoire Central des Industries Electriques)
Conformity certificate	LCIE 01 ATEX 6074
Sensor element	thermostatic bimetal
Contact type (1-pole)	opens with rising temperature
Service life	> 100,000 cycles
Max. Switching capacity	250VAC, 4 (1) A
Connection	Si HF - JZ 3 x 0.75mm ² , length 1m
Mounting	mounting bracket with nut M8 (see illustration)
Casing	aluminium, black anodised
Dimensions	length 110mm
Weight	approx. 0.20kg
Fitting position	variable
Operating / Storage temperature	-20 to +40°C (-4 to +104°F) / -45 to +70°C (-49 to +158°F)
Protection type / Protection class	IP65 / I (earthed)

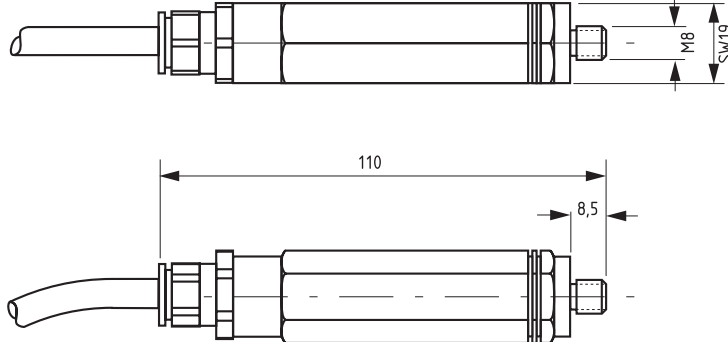
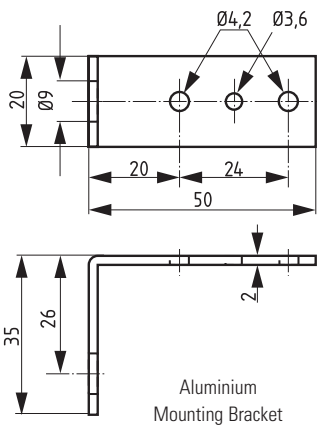

Art. No.	Ex protection type	Switch-off temperature	Switch temperature difference
01180.0-00	II 2 GD - EEx d IIC T6 IP6x T85°C	15°C (± 4K tolerance)	4K (± 1K tolerance)
01181.0-00	II 2 GD - EEx d IIC T6 IP6x T85°C	25°C (± 4K tolerance)	4K (± 1K tolerance)



- **Temperature limiting**
- **Wide voltage range**
- **Dynamic heating up**
- **Energy saving**
- **Compact**

Small heaters designed to prevent condensation and to ensure a minimum operating temperature in small enclosures.



Technical Data

Operating voltage	120-250V AC/DC*
Heating element	PTC resistor, self regulating and temperature limiting
Heater body	aluminium
Mounting	see Accessories
Fitting position	variable
Operating/Storage temperature	-45 to +70°C (-49 to +158°F)
Dimensions	length 45mm, Ø 10mm
Protection type / Protection class	IP32 / II (double insulated)
Approvals	VDE, UL File No. E150057
Accessories	mounting clips (see illustration)
Note	other voltages on request

*Operating with voltages below 140V AC/DC reduces heating performance by approx. 10%.

Example of connection

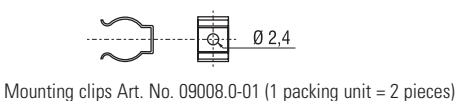
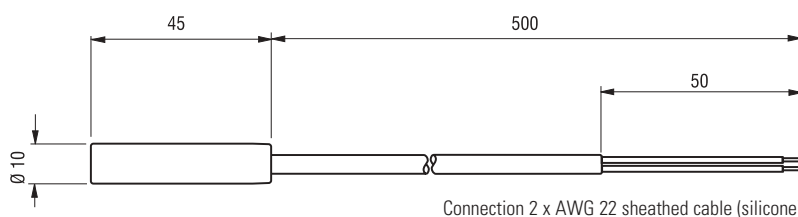
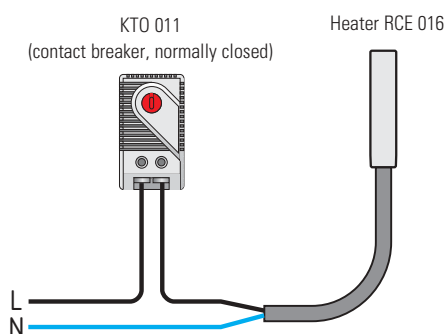

Art. No.	Heating capacity*	Inrush current max.	Surface temperature (approx.)	Connection	Weight (approx.)
01622.0-00	5W	2.0A	165°C	2 x AWG 22 sheathed cable (silicone)	20g
01623.0-00	9W	2.5A	175°C	2 x AWG 22 sheathed cable (silicone)	20g

*at 20°C (68°F) ambient temperature



- **Temperature limiting**
- **Wide voltage range**
- **Dynamic heating up**
- **Energy saving**
- **Compact**

These small heaters are designed to prevent condensation and to ensure a minimum operating temperature in small enclosures.



Technical Data

Operating voltage	120-250V AC/DC*
Heating element	PTC resistor, self regulating and temperature limiting
Heater body	aluminium, anodised
Mounting	screw fixing
Fitting position	variable
Operating/Storage temperature	-45 to +70°C (-49 to +158°F)
Protection type / Protection class	IP32 / II (double insulated)
Approvals	VDE, UL File No. E150057
Note	other voltages on request

*Operating with voltages below 140V AC/DC reduces heating performance by approx. 10%.

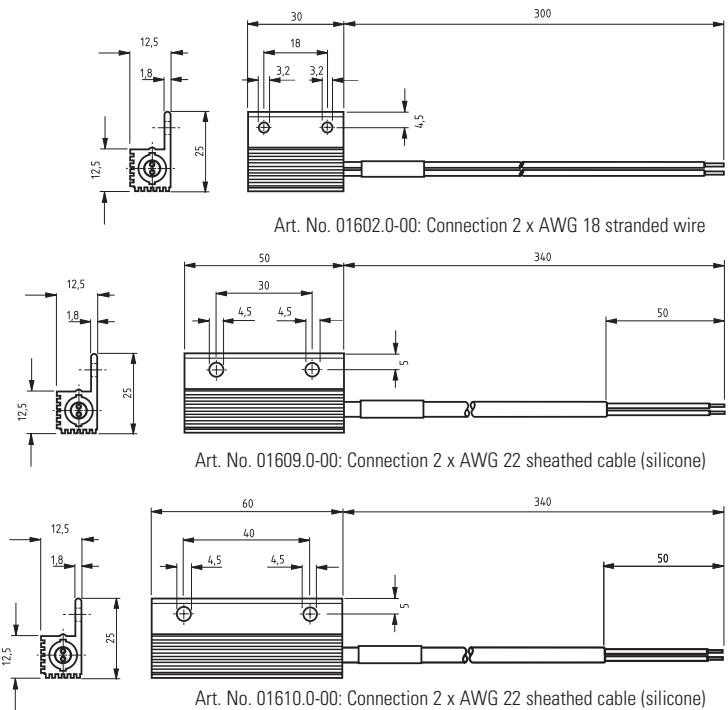
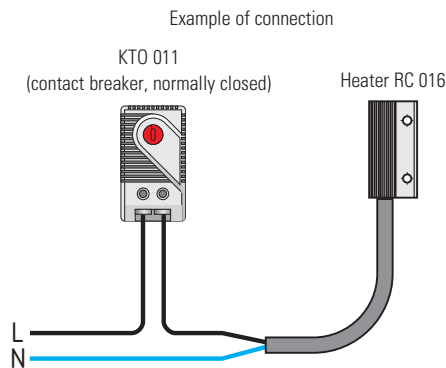

Art. No.	Heating capacity*	Inrush current max.	Surface temperature (approx.)	Connection	Weight (approx.)
01602.0-00	8W	2.0A	150°C	2 x AWG 18 stranded wire	20g
01609.0-00	10W	2.5A	155°C	2 x AWG 22 sheathed cable (silicone)	30g
01610.0-00	13W	3.0A	170°C	2 x AWG 22 sheathed cable (silicone)	40g

*at 20°C (68°F) ambient temperature



- Adjustable relative humidity
- Change-over contact
- High switching capacity
- Easily accessible terminals
- Clip fixing

The electromechanical thermostat MRF 012 is designed to control enclosure heaters so that the dew point is raised when a critical relative humidity of 65% is exceeded. In this way condensation and corrosion is effectively prevented.



Technical Data

Switch difference*	4% RH ($\pm 3\%$ tolerance)
permissible air velocity	15m/sec
Contact type	change-over contact
Contact resistance	< 10m Ω
Service life	> 50,000 cycles
Min. Switching capacity	20V AC/DC, 100mA
Max. Switching capacity	250VAC, 5 (0.2) A
EMC	acc. to EN 55014-1-2, EN 61000-3-2, EN 61000-3-3
Connection	3-pole terminal for 2.5mm ² , clamping torque 0.5Nm max.: rigid wire 2.5mm ² stranded wire (with wire end ferrule) 1.5mm ²
Mounting	clip for 35mm DIN rail, EN50022
Casing	plastic according to UL94 V-0, light grey
Dimensions	67 x 50 x 38mm
Weight	approx. 60g
Fitting position	variable
Operating / Storage temperature	0 to +60°C (+32 to +140°F) / -20 to +80°C (-4 to +176°F)
Protection type	IP20
Approvals	VDE and UL submitted

*at 50% RH

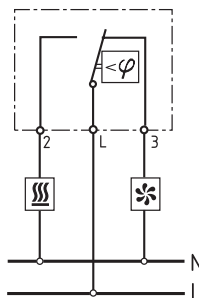
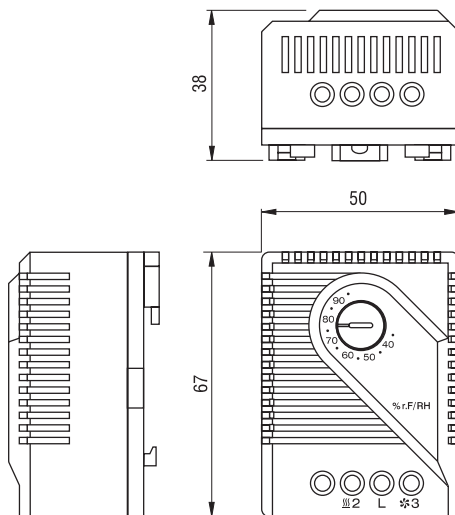

Art. No.	Setting range
01220.0-00	35 to 95% RH

Small, compact Thermostat KTO 011 / KTS 011



- **Large setting range**
- **Small size**
- **Simple to mount**
- **High switching performance**

KTO 011: Thermostat (normally closed); contact breaker for regulating heaters.

KTS 011: Thermostat (normally open); contact maker for regulating of filter fans and heat exchangers or for switching signal devised when temperature limit has been exceeded.



Technical Data

Switch temperature difference	7K (± 4K tolerance)
Sensor element	thermostatic bimetal
Contact type	snap-action contact
Contact resistance	< 10mΩ
Service life	> 100,000 cycles
Max. Switching capacity	250VAC, 10 (2) A 120VAC, 15 (2) A DC 30W
EMC	acc. to EN 55014-1-2, EN 61000-3-2, EN 61000-3-3
Connection	2-pole terminal, clamping torque 0.5Nm max.: rigid wire 2.5mm ² stranded wire (with wire end ferrule) 1.5mm ²
Mounting	clip for 35mm DIN rail, EN60715 (or for exit filter EF 118 Series)
Casing	plastic according to UL94 V-0, light grey
Dimensions	60 x 33 x 43mm
Weight	approx. 40g
Fitting position	variable
Operating / Storage temperature	-45 to +80°C (-49 to +176°F)
Protection type	IP20

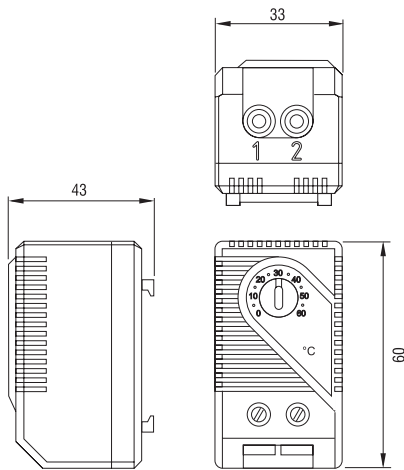

Thermostat KTO 011 (NC)

Thermostat KTS 011 (NO)

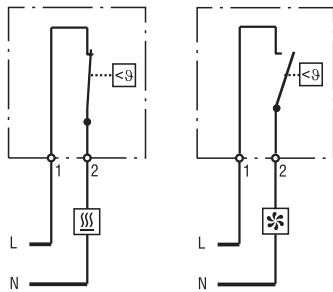

Connection diagrams

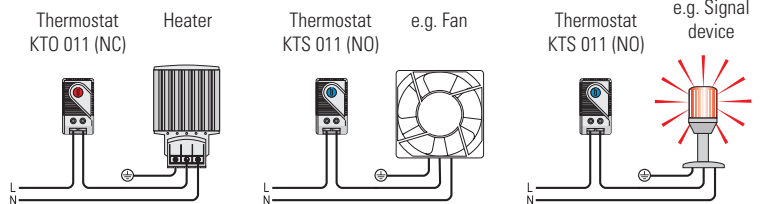
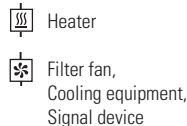

Example of connection

Setting range	Art. No. Contact Breaker (NC)	Art. No. Contact Maker (NO)	Approvals
0 to +60°C	01140.0-00	01141.0-00	VDE
-10 to +50°C	01142.0-00	01143.0-00	VDE
+20 to +80°C	01159.0-00	01158.0-00	VDE
+32 to +140°F	01140.9-00	01141.9-00	UL File No. E164102
+14 to +122°F	01142.9-00	01143.9-00	UL File No. E164102
0 to +60°C	01146.9-00	01147.9-00	UL File No. E164102

Specifications are subject to change without notice. Errors and omissions excepted. Suitability of this product for its intended use and any associated risks must be determined by the end customer/ buyer in its final application. 28.07.2008

Compact Lamp KL 025 Series

Lamp shown with protective plastic cover (see Accessories)



- Magnetic or optional DIN rail mounting
- Energy-saving lamp
- Lamp without/with electrical socket
(choice of sockets)
- On/Off switch

The compact lamp KL 025 was especially designed for use in enclosures. A powerful magnet enables the lamp to be mounted freely in any desired position in metal enclosures saving time and installation problems. The integrated electrical socket allows the use of additional appliances.



Technical Data

Luminosity	900 Lm
Lamp type	compact fluorescent lamp with integral starter
Service life	5,000 h
Switch	on/off switch for lamp
Connection	3-pole terminal 2.5mm ² with cable clamp, torque 0.8Nm
Mounting	magnet fixing
Casing	plastic, light grey
Dimensions	355 x 65 x 70mm
Weight	approx. 1.0kg
Fitting position	variable
Operating/Storage temperature	-20 to +50°C (-4 to +122°F) / -45 to +70 °C (-49 to +158 °F)
Protection type	IP20
Accessories	lamp cover, Art. No. 09520.0-00 (see photo)

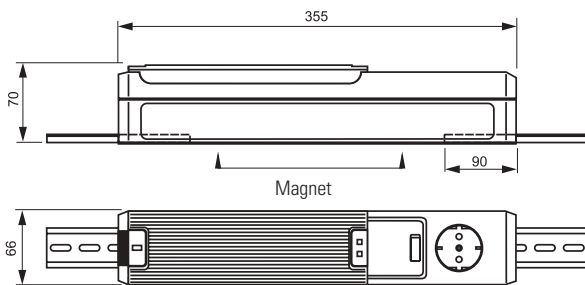

In plastic, aluminium or stainless steel cabinets the lamp can be fixed using screws together with inserted 35mm DIN rail sections.



Art. No.	Operating Voltage	Socket	Power consumption	Nominal Current	Protection class	Approvals
02500.0-00	230VAC, 50Hz	Germany (1)	11W (equals 75W light bulb)	16.0A	I (earthed)	VDE
02500.0-07	230VAC, 50Hz	none	11W (equals 75W light bulb)	-	II (double insulated)	-
02501.0-00	230VAC, 50Hz	France/Poland (2)	11W (equals 75W light bulb)	16.0A	I (earthed)	-
02502.0-00	230VAC, 50Hz	Switzerland (3)	11W (equals 75W light bulb)	10.0A	I (earthed)	-
02510.0-00	230VAC, 50Hz	UK/Ireland (4)	11W (equals 75W light bulb)	13.0A	I (earthed)	-
02512.0-00	230VAC, 50Hz	Italy (6)	11W (equals 75W light bulb)	16.0A	I (earthed)	-
02505.9-00	120VAC, 60Hz	USA/Canada (5)	9W (equals 60W light bulb)	15.0A	I (earthed)	-
02505.9-01	120VAC, 60Hz	none	9W (equals 60W light bulb)	-	II (double insulated)	-



- Compact**
- Flat design**
- High air through-flow**
- Temperature safety cut-out**
- Clip fixing**

The compact high-performance fan heater prevents formation of condensation in control or switch systems and provides an evenly distributed interior air temperature in enclosures. This fan heater is available without fan (HV 031) as well as with fan (HVL 031).



Technical Data

HV 031	Heater without fan (fan mounting kit included)
HVL 031	Heater with fan
Heating element	high performance cartridge
Temperature safety cut-out	to protect against overheating in case of fan failure
Heater body	die-cast aluminium (glass bead blasted)
Connection	3-pole screw connector 2.5mm ² , clamping torque 0.8Nm
Connection casing	plastic according to UL94 V-0, black
Mounting	clip for 35mm DIN rail, EN 50022
Fitting position	horizontal
Operating/Storage temperature	-45 to +70°C (-49 to +158°F)
Protection type / Protection class	IP20 / I (earthed)
*Axial fan, ball bearing	airflow see table service life 50,000h at 25°C (77°F)
*Connection (axial fan)	2-pole screw connector 2.5mm ² (L2/N2)
(*HVL 031 only)	
Approvals	UL File No. E187294 (only 230VAC: VDE)

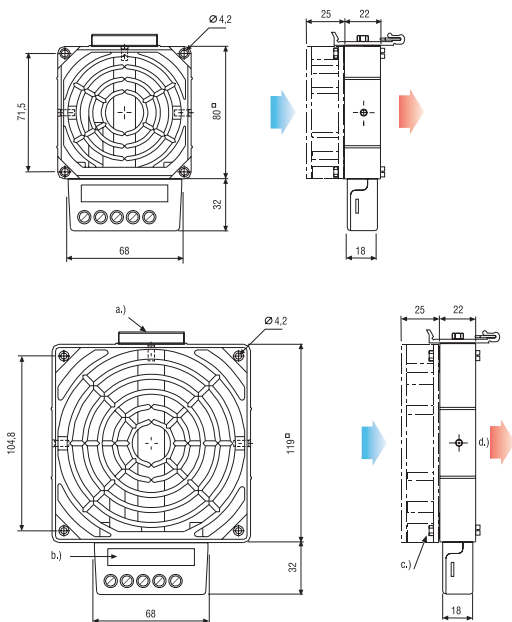

a.) Clip
b.) Type plate
c.) Axial fan
d.) Air direction



Important! Heater may only be operated together with fan. Danger of overheating!

Art. No. HV 031 230VAC, 50/60Hz	Art. No. HV 031 120VAC, 50/60Hz	Heating capacity	Dimensions	Weight (approx.)
03100.0-00	03100.9-00	100W	80 x 112 x 22mm	0.40kg
03101.0-00	03101.9-00	150W	80 x 112 x 22mm	0.40kg
03110.0-00	03110.9-00	200W	119 x 151 x 22mm	0.50kg
03111.0-00	03111.9-00	300W	119 x 151 x 22mm	0.50kg
03112.0-00	03112.9-00	400W	119 x 151 x 22mm	0.50kg

Art. No. HVL 031 230VAC, 50/60Hz	Art. No. HVL 031 120VAC, 50/60Hz	Heating capacity	Airflow min., free flow	Dimensions	Weight (approx.)
03102.0-00	03102.9-00	100W	35m ³ /h	80 x 112 x 47mm	0.60kg
03103.0-00	03103.9-00	150W	35m ³ /h	80 x 112 x 47mm	0.60kg
03113.0-00	03113.9-00	200W	108m ³ /h	119 x 151 x 47mm	0.90kg
03114.0-00	03114.9-00	300W	108m ³ /h	119 x 151 x 47mm	0.90kg
03115.0-00	03115.9-00	400W	108m ³ /h	119 x 151 x 47mm	0.90kg

Specifications are subject to change without notice. Suitability of this product for its intended use and any associated risks must be determined by the end customer/buyer in its final application. 24.04.2006

Compact Fan Heater Series HGL 046

250W, 400W



- Compact Design**
- Clip fixing**
- Long service life**
- Maintenance free**
- Temperature safety cut-out**

Compact fan heater prevents formation of condensation. The integrated high performance axial fan provides forced air circulation and so guarantees an even temperature in enclosures. With internal terminal connector.



Technical Data

Heating element	resistance heater
Temperature safety cut-out	to protect against overheating in case of fan failure
Heater body	anodised extruded aluminium profile
Surface temperature	max. 75°C (400W)
Axial fan, ball bearing	Airflow, free flow AC: 45m³/h (50Hz) or 54m³/h (60Hz) DC: 54m³/h service life 50,000h at 25°C (77°F)
Connection	internal connection terminal 1.5mm² with cable clamp, clamping torque 0.8Nm
Connection casing	plastic according to UL94 V-0, black
Mounting	clip for 35mm DIN rail, EN 50022
Fitting position	vertical
Operating/Storage temperature	-45 to +70°C (-49 to +158°F)
Protection type / Protection class	IP20 / I (earthed)

Note: In the case of 24VDC and 48VDC the fan heater has to be switched via a relay. For this purpose we recommend our electronic relay SM 010 (Art. No. 01000.0-00 and 01001.0-00).

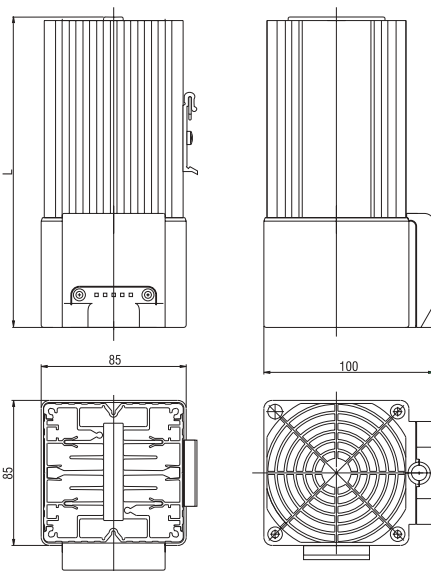

View from below

Electronic relay SM 010

Control contact
e.g. Temperature regulator KTO 011

Control contact
e.g. Temperature regulator KTO 011

Heater
Fan Heater HGL 046 (DC 48V) with temperature safety cut-out

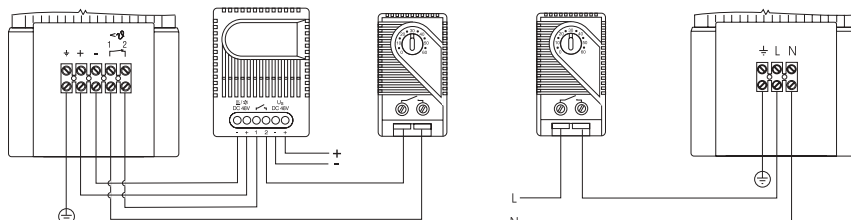

Heater
Fan Heater HGL 046 (AC 230V and 120V) with temperature safety cut-out

Art. No.	Operating voltage	Heating capacity	Length (L)	Weight (approx.)	Approvals
04640.0-00	230VAC, 50/60Hz	250W	182mm	1.10kg	VDE + UL File No. E150057
04641.0-00	230VAC, 50/60Hz	400W	222mm	1.40kg	VDE + UL File No. E150057
04640.9-00	120VAC, 50/60Hz	250W	182mm	1.10kg	VDE + UL File No. E150057
04641.9-00	120VAC, 50/60Hz	400W	222mm	1.40kg	VDE + UL File No. E150057
04640.1-00	24VDC	250W	182mm	1.10kg	-
04640.2-00	48VDC	250W	182mm	1.10kg	-
04641.2-00	48VDC	400W	222mm	1.40kg	-



- **Dynamic heating up**
- **Energy saving**
- **Wide voltage range**
- **Temperature limiting**
- **Clip fixing**

The heaters are used in enclosures where condensation is to be prevented or the temperature may not fall below a minimum value. In this way corrosion is avoided and an even temperature is ensured.



Technical Data

Heating element	PTC resistor, self regulating and temperature limiting
Heater body	extruded aluminium profile, anodised
Mounting	clip for 35mm DIN rail, EN 50022
Fitting position	vertical
Operating/Storage temperature	-45 to +70°C (-49 to +158°F)
Protection type / Protection class	IP54 / I (earthed)
Accessories	screw fixing, Art. No. 09024.0-00 (1 packing unit = 2 pieces)

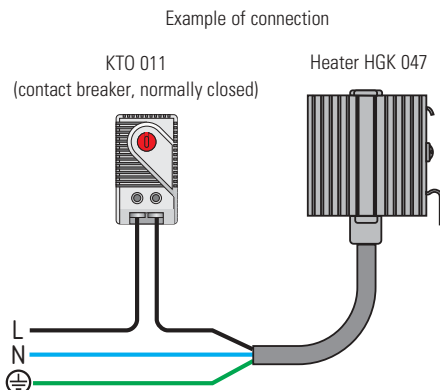
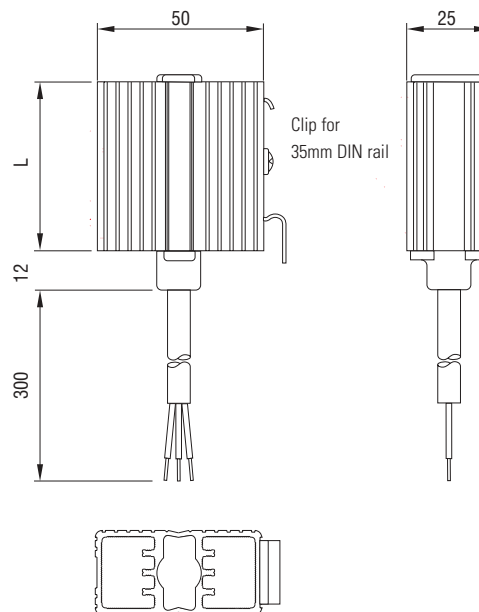

Art. No.	Operating voltage	Heating capacity ¹⁾	Inrush current max.	Length (L)	Weight (approx.)	Connection	Approvals
04700.0-00	120-250V AC/DC ²⁾	10W	1.0A	50mm	0.10kg	3 x 0.5mm ² x 300mm sheathed cable (silicone)	VDE
04701.0-00	120-250V AC/DC ²⁾	20W	2.5A	60mm	0.20kg	3 x 0.5mm ² x 300mm sheathed cable (silicone)	VDE
04702.0-00	120-250V AC/DC ²⁾	30W	3.0A	70mm	0.20kg	3 x 0.5mm ² x 300mm sheathed cable (silicone)	VDE
04700.9-00	110-120V AC/DC	10W	1.0A	50mm	0.10kg	3 x AWG 20 x 300mm sheathed cable	UL File No. E150057
04701.9-00	110-120V AC/DC	20W	1.5A	60mm	0.20kg	3 x AWG 20 x 300mm sheathed cable	UL File No. E150057
04702.9-00	110-120V AC/DC	30W	1.5A	70mm	0.20kg	3 x AWG 20 x 300mm sheathed cable	UL File No. E150057

¹⁾at 20°C (68°F) ambient temperature ²⁾Operating with voltages below 140V AC/DC reduces heating performance by approx. 10%.



- **Pressure clamp connectors**
- **Dynamic heating up**
- **Wide voltage range**
- **Temperature limiting**
- **Energy saving**
- **Clip fixing**
- **Quick installation**

These heaters are used in enclosures where damage from condensation must be prevented, or where the temperature may not fall below a minimum value. The aluminium profile heater body design has a chimney effect and distributes the heat evenly. The pressure clamp connectors save time and simplify installation.



Technical Data

Operating voltage	120-250V AC/DC*
Heating element	PTC resistor, self regulating and temperature limiting
Heater body	extruded aluminium profile, anodised
Connection	3 pressure clamps for stranded wire 0.5-1.5mm ² (with wire end ferrule) and rigid wire 0.5-2.5mm ²
Connection casing	plastic according to UL94 V-0, black
Mounting	clip for 35mm DIN rail, EN 50022
Fitting position	vertical
Operating/Storage temperature	-45 to +70°C (-49 to +158°F)
Protection type / Protection class	IP20 / I (earthed)
Approvals	VDE, UL File No. E150057
Accessories	screw fixing, Art. No. 09024.0-00 (1 packing unit = 2 pieces)

*Operating with voltages below 140V AC/DC reduces heating performance by approx. 10%.

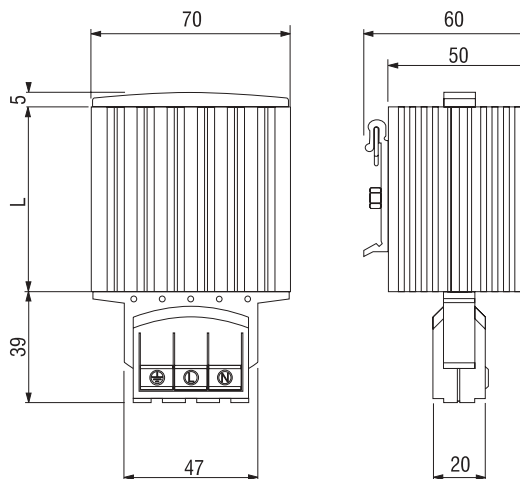
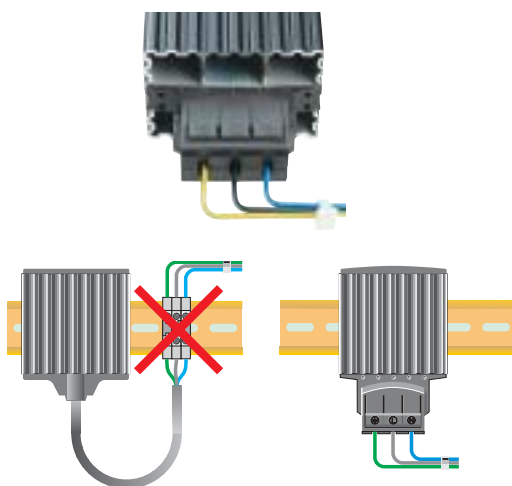

Art. No.	Heating capacity*	Inrush current max.	Length (L)	Weight (approx.)
14000.0-00	15W	1.5A	65mm	0.30kg
14001.0-00	30W	3.0A	65mm	0.30kg
14003.0-00	45W	3.5A	65mm	0.30kg
14005.0-00	60W	2.5A	140mm	0.40kg
14006.0-00	75W	4.0A	140mm	0.50kg
14007.0-00	100W	4.5A	140mm	0.50kg
14008.0-00	150W	9.0A	220mm	0.70kg

*at 20°C (68°F) ambient temperature

Mechanical Thermostat FZK 011



- **Adjustable temperature**
- **High switching capacity**
- **Small hysteresis**
- **Terminals easily accessible**
- **Clip fixing**
- **Change-over contact**

The mechanical thermostat is used for controlling heating and cooling equipment, filter fans or signal devices. The thermostat registers the surrounding air and can switch both inductive and resistive loads via snap-action contact.



Technical Data

Switch temperature difference	4K (± 1.5K tolerance)*
Sensor element	thermostatic bimetal
Contact type	change-over snap-action contact
Contact resistance	< 10mOhm
Service life	> 100,000 cycles
Max. Switching capacity, NC	250VAC, 10 (4) A
	DC 30W
Max. Switching capacity, NO	250VAC, 5 (2) A
	DC 30W
EMC	acc. to EN 55014-1-2, EN 61000-3-2, EN 61000-3-3
Connection	4-pole terminal for 2.5mm ² , clamping torque 0.8Nm
Mounting	clip for 35mm DIN rail, EN50022
Casing	plastic according to UL94 V-0, light grey
Dimensions	67 x 50 x 38mm
Weight	approx. 0.10kg
Fitting position	variable
Operating/Storage temperature	-20 to +80 °C (-4 to +176 °F) / -45 to +80 °C (-49 to +176 °F)
Protection type	IP20
Approvals	-

*Connecting terminal "N" (RF heating resistor) causes the thermal feedback to work and so reduces the switch temperature difference to approx. 0.5K.

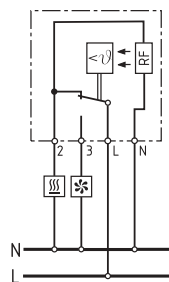
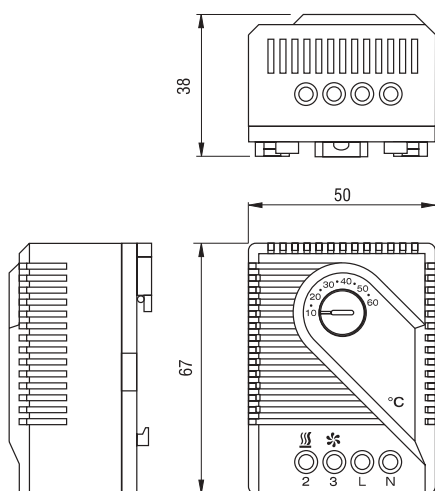

Load 1 = Enclosure heater
Load 2 = Filter fan, Cooling equipment, Signal device

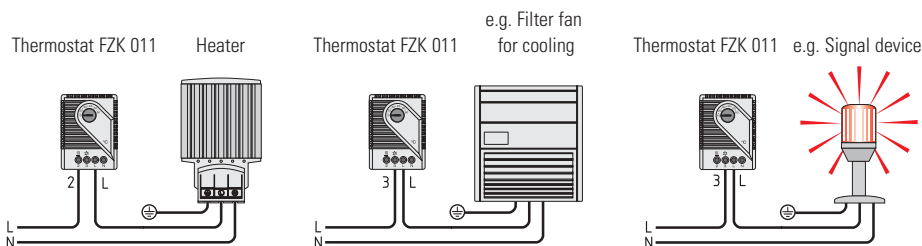

Examples of connection

Art. No.	Operating voltage*	Setting range
01170.0-00	230VAC	+ 5 to +60°C
01170.0-02	230VAC	-20 to +30°C

*operating voltage 120VAC with setting range in °F upon request

Tamperproof Thermostats (Pre-set) FTO 011 / FTS 011

- Small size
- Default temperature settings
- Easy to install
- High switching tolerance



Tamperproof (Pre-set) Thermostat FTO 011

Contact breaker / NC (red casing) for regulating heaters or for switching signal devices when temperature has fallen below the minimum value. The contact opens when temperature is rising.

Tamperproof (Pre-set) Thermostat FTS 011

Contact maker / NO (blue casing) for regulating filter fans, heat exchangers, cooling devices or for switching signal devices when temperature limit has been exceeded. The contact closes when temperature is rising.



Technical Data

Sensor element	thermostatic bimetal
Contact type	snap-action contact
Contact resistance	< 20mΩ
Service life	> 100,000 cycles
Max. switching capacity	240V AC, 5 (1.6)A 120 VAC, 10 (2)A DC 30W
Max. inrush current	AC 10A
EMC	acc. to EN 55014-1-2, EN 61000-3-2, EN 61000-3-3
Connection	2-pole terminal for 2.5mm ² , torque 0.8Nm max.
Mounting	clip for 35mm DIN rail, EN 50022
Casing	plastic according to UL94 V-0, light grey
Dimensions	47 x 33 x 33mm
Weight	approx. 23g
Fitting position	variable
Operating/Storage temperature	-20 to +80°C (-4 to +176°F) / -45 to +80°C (-49 to +176°F)
Prot. type	IP20
Approvals	VDE + UL File No. E164102

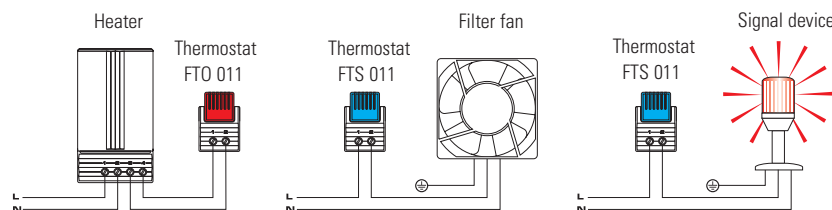
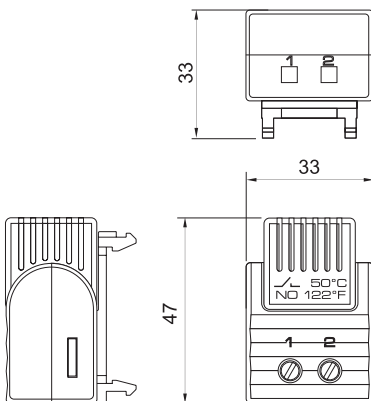

Example of connection

Art. No.	Contact	Switch-off temperature	Switch-on temperature
01160.0-00	Contact breaker (NC)	15°C / 59°F (± 5K tolerance)	5°C / 41°F (± 5K tolerance)
01160.0-01	Contact breaker (NC)	25°C / 77°F (± 5K tolerance)	15°C / 59°F (± 5K tolerance)
		Switch-on temperature	Switch-off temperature
01161.0-00	Contact maker (NO)	50°C / 122°F (± 6K tolerance)	40°C / 104°F (± 7K tolerance)
01161.0-01	Contact maker (NO)	60°C / 140°F (± 6K tolerance)	50°C / 122°F (± 7K tolerance)
01161.0-02	Contact maker (NO)	35°C / 95°F (± 6K tolerance)	25°C / 77°F (± 7K tolerance)

Tamperproof Dual-Thermostat (Pre-set) FTD 011

- **NO and NC in one casing**
- **Default temperature settings**
- **High switching accuracy**
- **Clip fixing**



Two thermostats in one casing:

Tamperproof (Pre-set) Thermostat/Contact breaker (NC) for regulating heaters or for switching signal devices when temperature has fallen below the minimum value. The contact opens when temperature is rising.

Tamperproof (Pre-set) Thermostat/Contact maker (NO) for regulating filter fans, heat exchangers or for switching signal devices when temperature limit has been exceeded. The contact closes when temperature is rising.

Heaters and cooling equipment can be switched independently from each other with a temperature offset as opposed to the usual change-over contacts.



Technical Data

Sensor element	thermostatic bimetal
Contact type	snap-action contact
Contact resistance	< 20mΩ
Service life	> 100,000 cycles
Max. switching capacity	240V AC, 5 (1.6)A 120V AC, 10 (2)A DC 30W
Max. inrush current	AC 10A
EMC	acc. to EN 55014-1-2, EN 61000-3-2, EN 61000-3-3
Connection	4-pole terminal for 2.5mm ² , torque 0.8Nm max.
Mounting	clip for 35mm DIN rail, EN 50022
Casing	plastic according to UL94 V-0, light grey
Dimensions	47 x 63 x 33mm
Weight	approx. 40g
Fitting position	variable
Operating/Storage temperature	-20 to +80°C (-4 to +176°F) / -45 to +80°C (-49 to +176°F)
Prot. type	IP20
Approvals	VDE + UL File No. E164102

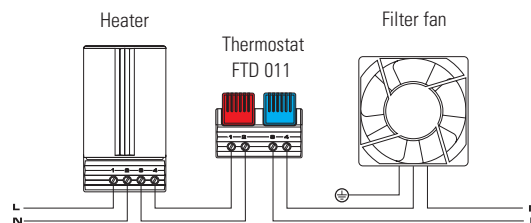
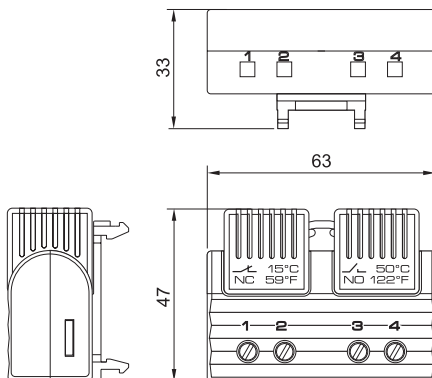

Example of connection

Art. No.	Contact breaker (NC)		Contact maker (NO)	
	Switch-off temperature	Switch-on temperature	Switch-on temperature	Switch-off temperature
01163.0-00	15°C / 59°F (± 5K tolerance)	5°C / 41°F (± 5K tolerance)	50°C / 122°F (± 6K tolerance)	40°C / 104°F (± 7K tolerance)
01163.0-01	25°C / 77°F (± 5K tolerance)	15°C / 59°F (± 5K tolerance)	60°C / 140°F (± 6K tolerance)	50°C / 122°F (± 7K tolerance)
01163.0-02	15°C / 59°F (± 5K tolerance)	5°C / 41°F (± 5K tolerance)	35°C / 95°F (± 6K tolerance)	25°C / 77°F (± 7K tolerance)
01163.0-03	25°C / 77°F (± 5K tolerance)	15°C / 59°F (± 5K tolerance)	50°C / 122°F (± 6K tolerance)	40°C / 104°F (± 7K tolerance)

Art. No.	Contact maker (NO)		Contact maker (NO)	
	Switch-on temperature	Switch-off temperature	Switch-on temperature	Switch-off temperature
01164.0-00	50°C / 122°F (± 6K tolerance)	40°C / 104°F (± 7K tolerance)	60°C / 140°F (± 6K tolerance)	50°C / 122°F (± 7K tolerance)

Outdoor Filter Fan FF 018 Series



- Filter changeable from outside**
- Safe, lockable**
- Impact resistant**
- Weather proof**

The outdoor filter fan can be used in outdoor enclosures where warm air has to be dissipated on account of increased thermic development. To clean and exchange the filter mat, it is only necessary to open the lockable door of the outdoor hood. A protection type of IP55 is achieved due to the special design of the hood and the use of fine filter mats. The plastic casing is impact resistant, highly weather proof and resistant to UV light.



Technical Data

Axial fan, ball bearing	service life min. 50,000h at 25°C/77°F (65% RH) fan body aluminium, rotor plastic
Connection	2 wires with pressure clamps 2.5mm ² , length 100mm
Filter fan and exit filter casing	casing material high impact plastic ASA, light grey burning behaviour according to UL94 H-B; high resistance to weather and UV
Mounting frame	with double industrial adhesive band for fixing to the outside of enclosure; certain operating circumstances can make the additional use of screws necessary (see drilling template); included in the delivery of the filter fans is a template for the enclosure cut-out.
Filter mat	F5 acc. to DIN EN 779, filtering degree 98%
Filter material	synthetic fibre with progressive construction, temperature resistant to 100°C, self-extinguishing class F1; moisture resistant to 100% RH
Operating/Storage temperature	-45 to +70°C (-49 to +158°F)
Protection type	IP55
Protection class	I (earthed)
Approvals	UL File No. E234324

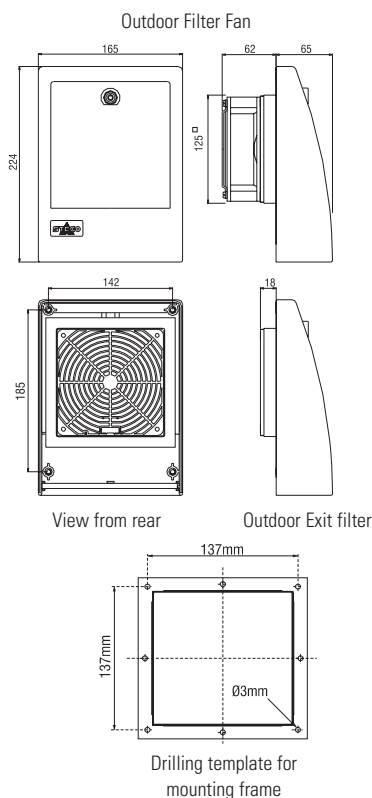

The hood is fixed permanently to the enclosure from the inside using screws. Filter mats can be easily changed from outside the enclosure through the lockable door in the hood.

Outdoor Filter Fan FF 018 Series

Art. No.	Operating voltage	Air volume, free flow	Current consumption	Power consumption	Average noise level (DIN EN ISO 4871)	Depth in enclosure	Enclosure cut-out	Weight (approx.)
01821.0-00	230VAC, 50Hz	20m ³ /h	100mA	15W	40dB (A)	62mm	125 x 125mm + 0.4	1.20kg
01821.0-02	120VAC, 60Hz	23m ³ /h	180mA	15W	40dB (A)	62mm	125 x 125mm + 0.4	1.20kg

Exit Filter EF 118 Series

Art. No.	Depth in enclosure	Enclosure cut-out	Weight (approx.)	Filter mat	Protection type
11821.0-00	16mm	125 x 125mm + 0.4	0.60kg	F5 acc. to DIN EN 779, filtering degree 98%	IP55

Filter Mats FFM 086

Filter mat	122 x 122mm
F5 (1 packing unit = 3 pcs.)	Art. No. 08607.0-00



High through-flow air volume

Functional design

Time-saving installation

Filter fans are used to provide an optimum climate in enclosures. The interior temperature of an enclosure can be reduced by channelling cooler filtered outside air into the enclosure thus expelling heated internal air. The resulting air flow prevents formation of localised hot pocket and protects the electronic components from overheating. The high-performance axial fan provides high air circulation.



Technical Data

Axial fan, ball bearing	service life min. 50,000h at 25°C/77°F (65% RH) fan body aluminium, rotor metal
Connection	3-pole clamp for 2.5mm ² , clamping torque 0.8Nm
Filter fan and exit filter casing	plastic according to UL94 V-0, light grey
Mounting frame	with double industrial adhesive band for fixing to the outside of enclosure; certain operating circumstances can make the additional use of screws necessary (see drilling template); included in the delivery of the filter fans is a template for the enclosure cut-out
Filter mat	G4 acc. to DIN EN 779, filtering degree 94%
Filter material	synthetic fibre with progressive construction, temperature resistant to 100°C, self-extinguishing class F1; moisture resistant to 100% RH, reusable – cleaning by washing or vacuuming
Operating/Storage temperature	-45 to +70°C (-49 to +158°F)
Prot. Type / Protection class	IP54* / I (earthed)

*Using fine filter mats type F5 increases the protection type to IP55, but reduces the air volume.

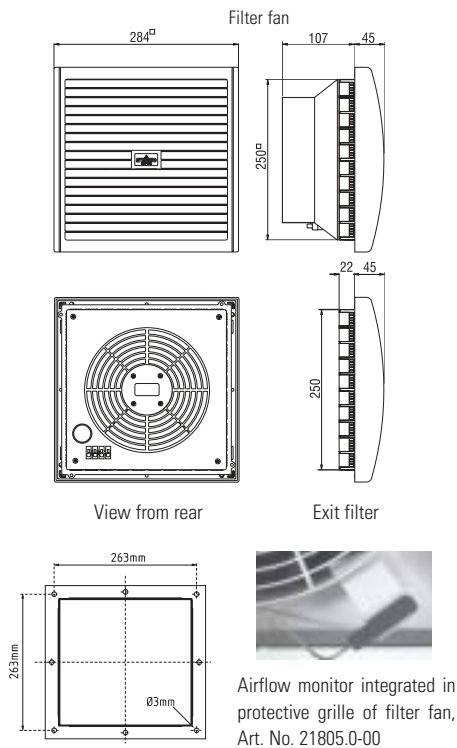

Drilling template for mounting frame

Filter Fan FF 018 Series

Art. No.	Operating voltage	Air volume, free flow	Air volume with exit filter	Current consumption	Power consumption	Average noise level (DIN EN ISO 4871)	Depth in enclosure	Enclosure cut-out	Weight (approx.)	Approvals
01805.0-00	230VAC, 50Hz	550m ³ /h	300m ³ /h	300mA	64W	65dB (A)	107mm	250 x 250mm + 0.4	2.70kg	UL File No. E234324
01805.0-01	120VAC, 50Hz	632m ³ /h	345m ³ /h	780mA	85W	65dB (A)	107mm	250 x 250mm + 0.4	2.70kg	UL File No. E234324

Exit Filter EF 118 Series

Art. No.	Depth in enclosure	Enclosure cut-out	Weight (approx.)	Filter mat	Protection type
11803.0-00	22mm	250 x 250mm + 0.4	1.00kg	G4 acc. to DIN EN 779, filtering degree 94%	IP54*

*Using fine filter mats type F5 increases the protection type to IP55, but reduces the air volume.

Filter Mats FM 086 / FFM 086

Filter mat	247 x 247mm
G4 (1 packing unit = 3 pcs.)	Art. No. 08608.0-00
F5 (1 packing unit = 3 pcs.)	Art. No. 08609.0-00

Filter Fan with Airflow Monitor FFLC 218 (Normally Closed)

Art. No.	Operating voltage	Air volume, free flow	Air volume with exit filter	Current consumption	Power consumption	Average noise level (DIN EN ISO 4871)	Depth in enclosure	Enclosure cut-out	Weight (approx.)
21805.0-00	230VAC, 50Hz	550m ³ /h	300m ³ /h	300mA	64W	65dB (A)	107mm	250 x 250mm + 0.4	2.70kg
21805.0-01	120VAC, 50Hz	632m ³ /h	345m ³ /h	780mA	85W	65dB (A)	107mm	250 x 250mm + 0.4	2.70kg

For technical data see Airflow Monitor LC 013/LCF 013 (Normally Closed, Normally Open)

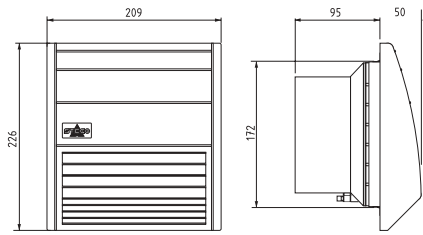

Filter Fan

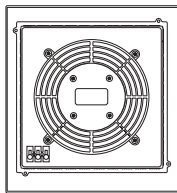

View from rear

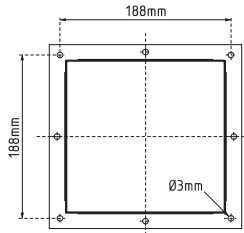

Drilling template for mounting frame

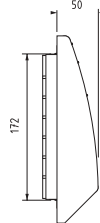

Exit filter



Airflow monitor integrated in protective grille of filter fan, e.g. Art. No. 21804.0-00

- **Low maintenance**
- **High through-flow air volume**
- **Functional design**
- **Time-saving installation**

Filter fans are used to provide an optimum climate in enclosures. The interior temperature of an enclosure can be reduced by channelling cooler filtered outside air into the enclosure thus expelling heated internal air. The resulting air flow prevents formation of localised hot pocket and protects the electronic components from overheating.



Technical Data

Axial fan, ball bearing	service life min. 50,000h at 25°C/77°F (65% RH) fan body aluminium, rotor metal
Connection	3-pole clamp for 2.5mm ² , clamping torque 0.8Nm
Filter fan and exit filter casing	plastic according to UL94 V-0, light grey
Mounting frame	with double industrial adhesive band for fixing to the outside of enclosure; certain operating circumstances can make the additional use of screws necessary (see drilling template); included in the delivery of the filter fans is a template for the enclosure cut-out
Filter mat	G4 acc. to DIN EN 779, filtering degree 94%
Filter material	synthetic fibre with progressive construction, temperature resistant to 100°C, self-extinguishing class F1; moisture resistant to 100% RH, reusable – cleaning by washing or vacuuming
Operating/Storage temperature	-45 to +70°C (-49 to +158°F)
Prot. Type / Protection class	IP54* / I (earthed)

*Using fine filter mats type F5 increases the protection type to IP55, but reduces the air volume.

Filter Fan FF 018 Series

Art. No.	Operating voltage	Air volume, free flow	Air volume with exit filter	Current consumption	Power consumption	Average noise level (DIN EN ISO 4871)	Depth in enclosure	Enclosure cut-out	Weight (approx.)	Approvals
01804.0-00	230VAC, 50Hz	200m ³ /h	125m ³ /h	320mA	45W	52dB (A)	95mm	176 x 176mm + 0.4	1.70kg	UL File No. E234324
01804.0-01	120VAC, 50Hz	230m ³ /h	143m ³ /h	470mA	39W	52dB (A)	95mm	176 x 176mm + 0.4	1.70kg	UL File No. E234324

Exit Filter EF 118 Series

Art. No.	Depth in enclosure	Enclosure cut-out	Weight (approx.)	Filter mat	Protection type
11802.0-00	16mm	176 x 176mm + 0.4	0.60kg	G4 acc. to DIN EN 779, filtering degree 94%	IP54*

*Using fine filter mats type F5 increases the protection type to IP55, but reduces the air volume.

Filter Mats FM 086 / FFM 086

Filter mat	168 x 168mm
G4 (1 packing unit = 3 pcs.)	Art. No. 08602.0-00
F5 (1 packing unit = 3 pcs.)	Art. No. 08605.0-00

Filter Fan with Airflow Monitor FFLC 218 (Normally Closed)

Art. No.	Operating voltage	Air volume, free flow	Air volume with exit filter	Current consumption	Power consumption	Average noise level (DIN EN ISO 4871)	Depth in enclosure	Enclosure cut-out	Weight (approx.)
21804.0-00	230VAC, 50Hz	200m ³ /h	125m ³ /h	320mA	45W	52dB (A)	95mm	176 x 176mm + 0.4	1.70kg
21804.0-01	120VAC, 50Hz	230m ³ /h	143m ³ /h	470mA	39W	52dB (A)	95mm	176 x 176mm + 0.4	1.70kg

For technical data see Airflow Monitor LC 013/LCF 013 (Normally Closed, Normally Open)



- Very low noise**
- Minimal depth in enclosure**
- High through-flow air volume**
- Uniform air circulation**
- High reliability**

Filter fans are used to provide an optimum climate in enclosures. The interior temperature of an enclosure can be reduced by channelling cooler filtered outside air into the enclosure thus expelling heated internal air. The resulting air flow prevents formation of localised hot pocket and protects the electronic components from overheating. **Four integrated axial fans** provide a particularly high and uniform air circulation thus contributing to higher reliability.



Technical Data

Axial fan, ball bearing	service life min. 50,000h at 25°C/77°F (65% RH) fan body aluminium, rotor plastic
Connection	3-pole clamp for 2.5mm ² , clamping torque 0.8Nm
Filter fan and exit filter casing	plastic according to UL94 V-0, light grey
Mounting frame	with double industrial adhesive band for fixing to the outside of enclosure; certain operating circumstances can make the additional use of screws necessary (see drilling template); included in the delivery of the filter fans is a template for the enclosure cut-out
Filter mat	G4 acc. to DIN EN 779, filtering degree 94%
Filter material	synthetic fibre with progressive construction, temperature resistant to 100°C, self-extinguishing class F1; moisture resistant to 100% RH, reusable – cleaning by washing or vacuuming
Operating/Storage temperature	-45 to +70°C (-49 to +158°F)
Prot. Type / Protection class	IP54* / I (earthed)

*Using fine filter mats type F5 increases the protection type to IP55, but reduces the air volume.

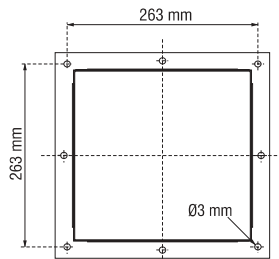
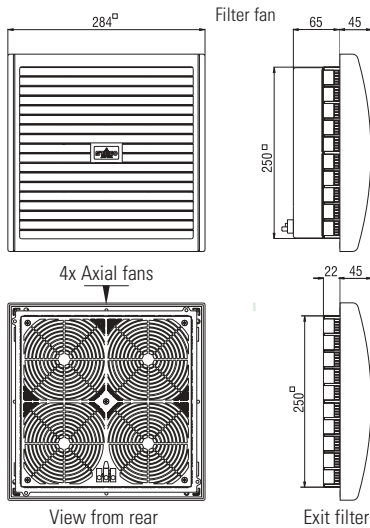

Drilling template for mounting frame

Filter Fan FF 018 Series

Art. No.	Operating voltage	Air volume, free flow	Air volume with exit filter	Current consumption	Power consumption	Average noise level (DIN EN ISO 4871)	Depth in enclosure	Enclosure cut-out	Weight (approx.)	Approvals
01803.0-00	230VAC, 50Hz	300m ³ /h	230 m ³ /h	400 mA	60W	53dB (A)	65mm	250 x 250mm + 0.4	3.30kg	UL File No. E234324
01803.0-01	120VAC, 50Hz	345m ³ /h	264 m ³ /h	700 mA	60W	53dB (A)	65mm	250 x 250mm + 0.4	3.30kg	UL File No. E234324

Exit Filter EF 118 Series

Art. No.	Depth in enclosure	Enclosure cut-out	Weight (approx.)	Filter mat	Protection type
11803.0-00	22mm	250 x 250mm + 0.4	1.00kg	G4 acc. to DIN EN 779, filtering degree 94%	IP54*

*Using fine filter mats type F5 increases the protection type to IP55, but reduces the air volume.

Filter Mats FM 086 / FFM 086

Filter mat	247 x 247mm
G4 (1 packing unit = 3 pcs.)	Art. No. 08608.0-00
F5 (1 packing unit = 3 pcs.)	Art. No. 08609.0-00



- **Very low noise**
- **Minimal depth in enclosure**
- **Functional design**
- **Time-saving installation**

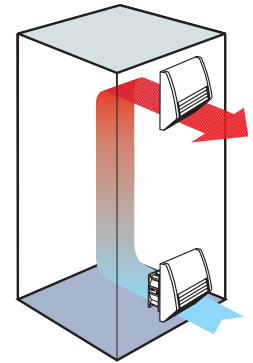

Enclosure air-conditioning using a filter fan and exit filter

Filter fans are used to provide an optimum climate in enclosures. The interior temperature of an enclosure can be reduced by channelling cooler filtered outside air into the enclosure thus expelling heated internal air. The resulting air flow prevents formation of localised hot pockets and protects the electronic components from overheating.



Technical Data

Axial fan, ball bearing	service life min. 50,000h at 25°C/77°F (65% RH) fan body aluminium, rotor plastic
Connection	2 wires with pressure clamps 2.5mm ² , length 100mm
Filter fan and exit filter casing	Plastic according to UL94 V-0, light grey
Mounting frame	with double industrial adhesive band for fixing to the outside of enclosure; certain operating circumstances can make the additional use of screws necessary (see drilling template); included in the delivery of the filter fans is a template for the enclosure cut-out
Filter mat	G4 acc. to DIN EN 779, filtering degree 94%
Filter material	synthetic fibre with progressive construction, temperature resistant to 100°C, self-extinguishing class F1; moisture resistant to 100% RH, reusable – cleaning by washing or vacuuming
Operating/Storage temperature	-45 to +70°C (-49 to +158°F)
Prot. Type / Protection class	IP54* / I (earthed)

*Using fine filter mats type F5 increases the protection type to IP55, but reduces the air volume.

Special features

The **self-adhesive seal** of the mounting frame prevents dust and water from entering the cabinet.

Functional design of the intake and exit fan hoods very effectively prevents direct intrusion of falling water and dust. The advantage is that the filter mat does not get so quickly contaminated with dirt and thus does not need to be exchanged so often.

The **air channelling** makes the filter fan particularly quiet in operation.

Functional and **modern design** enables time-saving assembly and maintenance.

All filter fan models are also available with **integrated airflow monitor**.

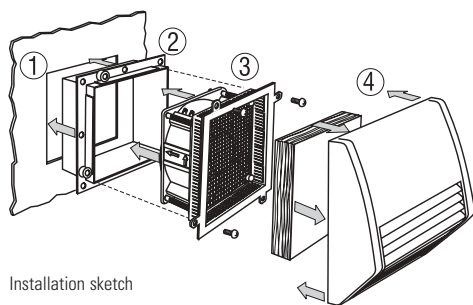

Installation sketch

Time-saving assembly and maintenance

STEGO's filter fans are easily connected and installed **from outside** the cabinet.

- 1.) Make cut-out in the cabinet wall. The cut edge of the cabinet opening should be free of dirt, filings and grease. A template for the enclosure cut-out is included in the delivery of the filter fan.
- 2.) Remove protective film from the sealing strips on the mounting frame. Press mounting frame into the cabinet opening. The frame stays permanently in the cabinet.
- 3.) Electrically connect the axial fan using the clip connectors. Push the unit into the mounting frame. Fix using screws.
- 4.) Insert the filter mat in the hood. Clip on. Finished.

Cleaning and changing the filter mat is quickly done. To change the filter mat simply remove the filter hood, insert the new mat and snap the hood back again. No tools required. Assembly and maintenance can easily be carried out by one person from outside.

Filter Fan FF 018 Series

Art. No.	Operating voltage	Air volume, free flow	Air volume with exit filter	Current consumption	Power consumption	Average noise level (DIN EN ISO 4871)	Depth in enclosure	Enclosure cut-out	Weight (approx.)	Approvals
01800.0-00	230VAC, 50Hz	21m ³ /h	16m ³ /h	80mA	13W	31dB (A)	45mm	97 x 97mm + 0.4	0.60kg	VDE + UL File No. E234324
01801.0-00	230VAC, 50Hz	55m ³ /h	42m ³ /h	100mA	15W	40dB (A)	58mm	125 x 125mm + 0.4	1.00kg	VDE + UL File No. E234324
01802.0-00	230VAC, 50Hz	102m ³ /h	68m ³ /h	100mA	15W	39dB (A)	86mm	176 x 176mm + 0.4	1.30kg	VDE + UL File No. E234324
01800.0-01	120VAC, 50Hz	24m ³ /h	18m ³ /h	160mA	13W	31dB (A)	45mm	97 x 97mm + 0.4	0.60kg	UL File No. E234324
01801.0-01	120VAC, 50Hz	63m ³ /h	48m ³ /h	180mA	15W	40dB (A)	58mm	125 x 125mm + 0.4	1.00kg	UL File No. E234324
01802.0-01	120VAC, 50Hz	117m ³ /h	78m ³ /h	180mA	15W	39dB (A)	86mm	176 x 176mm + 0.4	1.30kg	UL File No. E234324

Dimensional Drawing

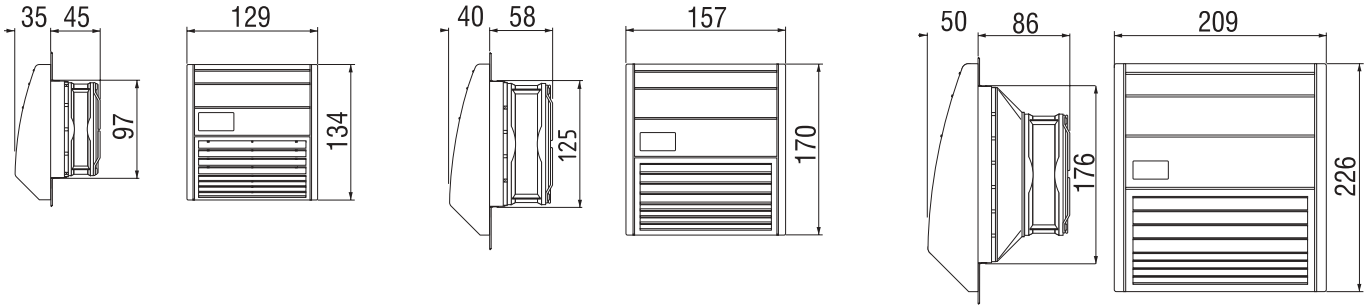

Drilling template for mounting frame



Exit Filter EF 118 Series

Art. No.	Depth in enclosure	Enclosure cut-out	Weight (approx.)	Filter mat	Protection type
11800.0-00	16mm	97 x 97mm + 0.4	0.30kg	G4 acc. to DIN EN 779, filtering degree 94%	IP54*
11801.0-00	16mm	125 x 125mm + 0.4	0.40kg	G4 acc. to DIN EN 779, filtering degree 94%	IP54*
11802.0-00	16mm	176 x 176mm + 0.4	0.60kg	G4 acc. to DIN EN 779, filtering degree 94%	IP54*

*Using fine filter mats type F5 increases the protection type to IP55, but reduces the air volume.

Filter Mats FM 086 / FFM 086

Filter mat	89 x 89mm	118 x 118mm	168 x 168mm
G4 (1 packing unit = 3 pcs.)	Art. No. 08600.0-00	Art. No. 08601.0-00	Art. No. 08602.0-00
F5 (1 packing unit = 3 pcs.)	Art. No. 08603.0-00	Art. No. 08604.0-00	Art. No. 08605.0-00

Filter Fan with Airflow Monitor FFLC 218 (Normally Closed)



Airflow monitor integrated in protective grille of filter fan, e.g. Art. No. 21800.0-00

Art. No.	Operating voltage	Air volume, free flow	Air volume with exit filter	Current consumption	Power consumption	Average noise level (DIN EN ISO 4871)	Depth in enclosure	Enclosure cut-out	Weight (approx.)
21800.0-00	230VAC, 50Hz	21m³/h	16m³/h	80mA	13W	31dB (A)	45mm	97 x 97mm + 0.4	0.60kg
21801.0-00	230VAC, 50Hz	55m³/h	42m³/h	100mA	15W	40dB (A)	58mm	125 x 125mm + 0.4	1.00kg
21802.0-00	230VAC, 50Hz	102m³/h	68m³/h	100mA	15W	39dB (A)	86mm	176 x 176mm + 0.4	1.30kg
21800.0-01	120VAC, 50Hz	24m³/h	18m³/h	160mA	13W	31dB (A)	45mm	97 x 97mm + 0.4	0.60kg
21801.0-01	120VAC, 50Hz	63m³/h	48m³/h	180mA	15W	40dB (A)	58mm	125 x 125mm + 0.4	1.00kg
21802.0-01	120VAC, 50Hz	117m³/h	78m³/h	180mA	15W	39dB (A)	86mm	176 x 176mm + 0.4	1.30kg

For technical data see Airflow Monitor LC 013/LCF 013 (Normally Closed, Normally Open)

Electronic Hygrotherm ETF 012



- **Temperature and humidity adjustable**
- **Optical operating display (LED)**
- **High switching capacity**
- **Clip fixing**

The electronic hygrotherm senses the ambient temperature and relative humidity in an enclosure with electric/electronic components, and turns on a heater (or alternatively, a fan) at either set point, helping prevent the formation of condensation in the enclosure. The LED integrated in the adjustment knob on the active controller is lit when the connected device is in operation.



Technical Data

Switch difference (temperature)	2K (± 1K tolerance)
Switch difference (humidity)	4% RH (± 1% tolerance)
Reaction time (humidity)	approx. 160 sec.
Contact type	change-over contact (relay)
Contact resistance	< 10mOhm
Service life	NC: 50,000 cycles NO: 100,000 cycles
Max. Switching capacity (Relay output)	NC: 240VAC, 6 (1) A NO: 240VAC, 8 (1.6) A NC: 120VAC, 6 (1) A NO: 120VAC, 8 (1.6) A 24VDC, 4A
EMC	acc. to EN 55014-1-2, EN 61000-3-2, EN 61000-3-3
Betriebsanzeige	LED
Connection	5-pole terminal 2.5mm ² , clamping torque 0.8Nm
Mounting	clip for 35mm DIN rail, EN50022
Casing	plastic according to UL94 V-0, light grey
Dimensions	77 x 60 x 43mm
Weight	approx. 0.20kg
Fitting position	vertical
Operating/Storage temperature	0 to +60°C (+32 to +140°F) / -20 to +80°C (-4 to +176°F)
Protection type	IP20

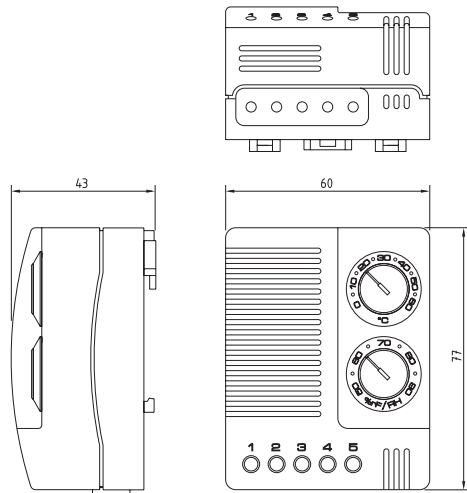

Connection diagram

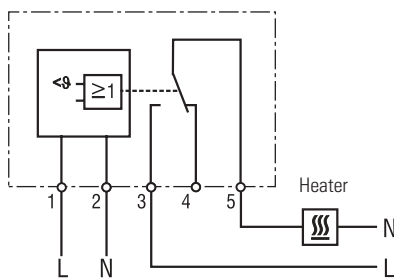

Example of connection

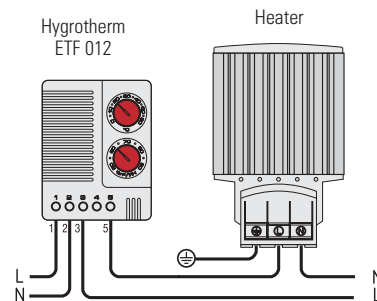

Art. No.	Operating voltage	Setting range temperature	Setting range humidity	Approval
01230.0-00	230VAC, 50/60Hz	0 to 60°C	50 to 90% RH	VDE + UL File No. E164102
01230.9-00	120VAC, 50/60Hz	32 to 140°F	50 to 90% RH	UL File No. E164102
01230.9-01	120VAC, 50/60Hz	0 to 60°C	50 to 90% RH	UL File No. E164102

Electronic Thermostat ET 011 (24VDC)



- **High DC breaking capacity**
- **Low hysteresis**
- **Adjustable temperature**
- **Change-over contact**
- **Clip fixing**

Electronic thermostat for regulating high performance DC 24V equipment. Heating or cooling appliances as well as signal devices can be switched via the potential free change-over contact. In comparison to mechanical thermostats, the ET 011 has a low hysteresis making the switching point and setting accuracy more precise.



Technical Data

Switch temperature difference	approx. 3K
Sensor element	PTC
Contact type	change-over
Contact resistance	< 10mOhm
Service life	> 100,000 cycles
Max. switching capacity	28VDC, 16A
EMC	acc. to EN 55014-1-2, EN 61000-3-2, EN 61000-3-3
Connection	5-pole terminal for 2.5mm ² , clamping torque 0.8Nm
Mounting	clip for 35mm DIN rail, EN 50022
Casing	plastic according to UL94 V-0, light grey
Dimensions	67 x 50 x 46mm
Weight	approx. 80g
Fitting position	vertical
Operating/Storage temperature	0 to +60 °C (32 to +140 °F) / -45 to +80 °C (-49 to +176 °F)
Protection type	IP20
Approvals	VDE and UL intended

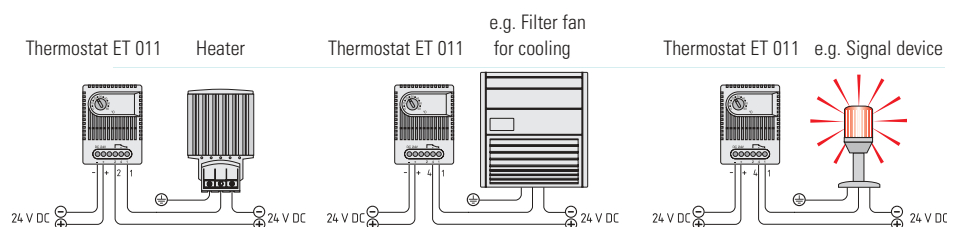
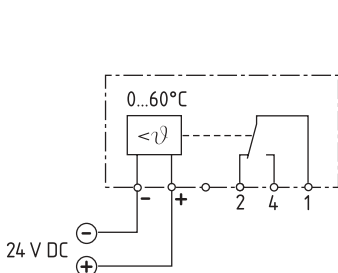
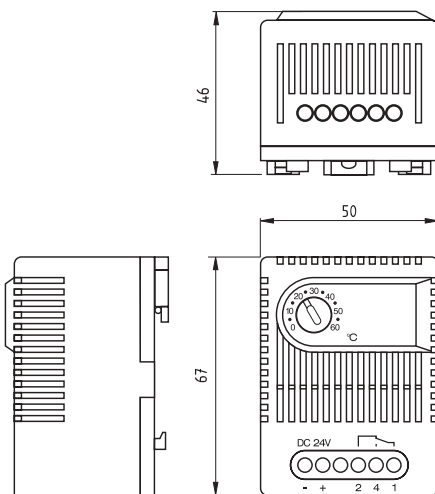

Examples of connection

Art. No.	Operating voltage	Setting range
01190.0-00	24VDC (20-28VDC)	0 to +60°C

Hand Lamp DL 026 Series with lamp holder

Lighting



Long-life energy saving lamp

Versatile



Technical Data

Luminosity	1000Lm
Lamp type	energy saving lamp, E27 socket
Service life	10,000h
Connection	power cable (2m) with Euro plug
Mounting	screws or fixing plate (self-adhesive)
Casing	plastic according to UL94 V-0, light grey
Weight	approx. 0.60kg
Fitting position	variable
Operating/Storage temperature	-20 to +50°C (-4 to +122°F) / -45 to +70 °C (-49 to +158 °F)
Protection type / Protection class	IP20 / II (double insulated)
Approvals	-
Included in delivery	lamp holder, hook and fixing plate
Note	120VAC and DC voltages on request

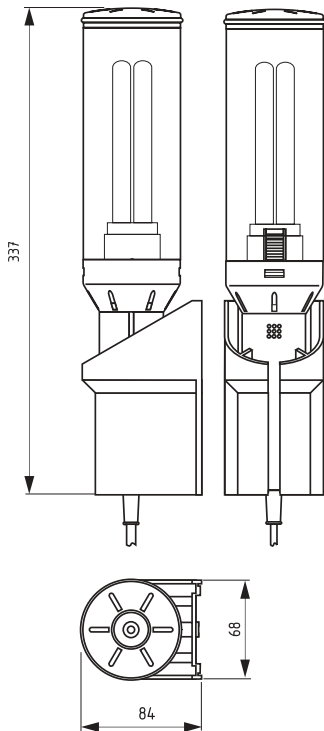

Specifications are subject to change without notice. Errors and omissions excepted. Suitability of this product for its intended use and any associated risks must be determined by the end customer/buyer in its final application. 24.04.2006

Art. No.	Operating voltage	Power consumption
02610.0-00	230VAC, 50Hz	20W (equals 100W light bulb)



- Large convection surface**
- Clip fixing**
- Ready for use**
- Maintenance free**

Compact convection heater for use in areas with explosion hazard for prevention of formation of condensation, temperature fluctuations and for protection against frost in transmitter housings, switch cabinets and measuring equipment.



Technical Data

Explosion protection according to EN	LCIE (Laboratoire Central des Industries Electriques)
Conformity certificate	LCIE 01 ATEX 6073
Heating element	high performance cartridge
Heater body	aluminium profile, black anodised
Connection	Si HF-JZ 3 x 0.75mm ² cable, length 1m
Connection PE	4mm ²
Mounting	clip for 35mm DIN rail, EN 50022
Fitting position	vertical
Operating / Storage temperature	-20 to +40°C (-4 to +104°F) / -45 to +70°C (-49 to +158°F)
Protection type / Protection class	IP65 / I (earthed)

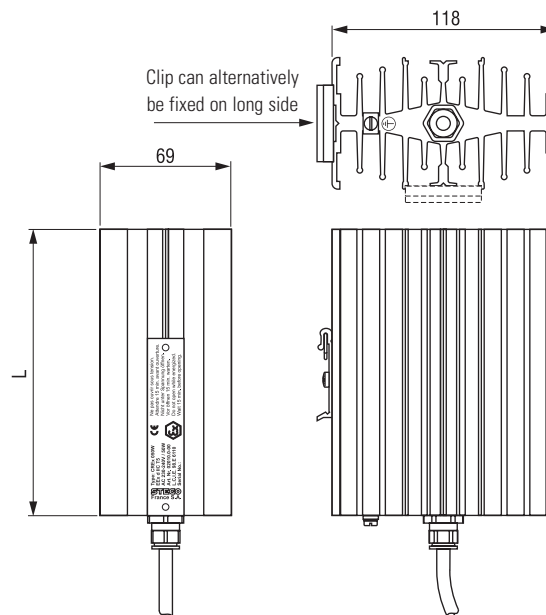

Art. No.	Operating voltage	Heating capacity	Ex protection type	Surface temperature	Length (L)	Weight (approx.)
02010.0-00	230-240VAC	50W	Ex II 2 GD - EEx d IIC T5 IP6x T100°C	100°C	150mm	1.30kg
02011.0-00	230-240VAC	100W	Ex II 2 GD - EEx d IIC T4 IP6x T135°C	135°C	180mm	1.50kg
02010.0-01	110-120VAC	50W	Ex II 2 GD - EEx d IIC T5 IP6x T100°C	100°C	150mm	1.30kg
02011.0-01	110-120VAC	100W	Ex II 2 GD - EEx d IIC T4 IP6x T135°C	135°C	180mm	1.50kg



- Compact heater
- Heating capacity adjusts to ambient temperature
- Adjustable temperature range
- Clip fixing
- Optical indicator
- Temperature safety cut-out

Semiconductor fan heaters prevent the formation of condensation and ensure an even temperature in switch and control equipment. The built-in regulator is used to set the desired temperature.



Technical Data

Heating element	PTC resistor, temperature limiting
Temperature safety cut-out	to protect against overheating in case of fan failure
Axial fan, ball bearing	airflow see table service life 50,000h at 25°C (77°F)
Connection	2-pole clamp 2.5mm ² , clamping torque 0.8Nm max.
Casing	plastic according to UL94 V-0, light grey
Optical indicator	thermostat control lamp
Mounting	clip for 35mm DIN rail, EN 60715
Fitting position	vertical
Dimensions	100 x 128 x 165mm
Operating / Storage temperature	-45 to +70°C (-49 to +158°F)
Protection type / Protection class	IP20 / II (double insulated)
Approvals	UL File No. E204590

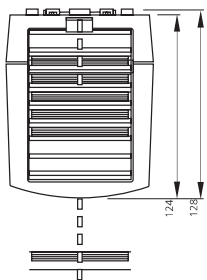
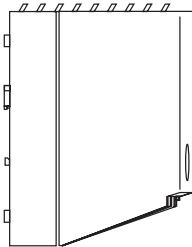
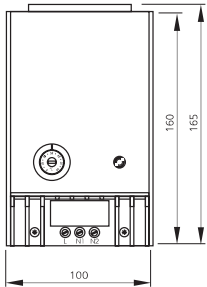

Heating capacity / Ambient temperature diagram CR 027 (50Hz)

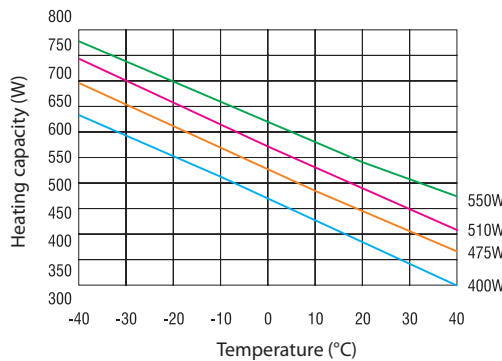

Heating capacity / Ambient temperature diagram CR 027 (60Hz)

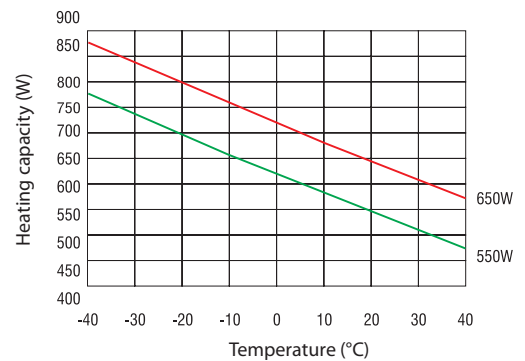

Art. No.	Operating voltage	Heating capacity* (50Hz)	Heating capacity* (60Hz)	Inrush current max.	Airflow, free flow	Setting range Temp. regulator	Weight (approx.)
02700.0-00	220-240VAC, 50/60Hz	475W	550W	11.0A	35m ³ /h	0 to +60°C	0.9kg
02701.0-00	220-240VAC, 50/60Hz	550W	650W	13.0A	45m ³ /h	0 to +60°C	1.1kg
02700.9-00	100-120VAC, 50/60Hz	400W	550W	14.0A	35m ³ /h	+32 to +140°F	0.9kg
02701.9-00	100-120VAC, 50/60Hz	510W	650W	15.0A	45m ³ /h	+32 to +140°F	1.1kg

*at 20°C (68°F) ambient temperature

Specifications are subject to change without notice. Errors and omissions excepted. Suitability of this product for its intended use and any associated risks must be determined by the end customer/buyer in its final application.

Heating



www.klinkmann.com

Helsinki
tel. +358 9 540 4940
automation@klinkmann.fi

St. Petersburg
tel. +7 812 327 3752
klinkmann@klinkmann.spb.ru

Moscow
tel. +7 495 641 1616
moscow@klinkmann.spb.ru

Yekaterinburg
tel. +7 343 376 5393
yekaterinburg@klinkmann.spb.ru

Mineralnye Vody
tel. +7 879 226 1934
pyatigorsk@klinkmann.spb.ru

Samara
tel. +7 846 342 6655
samara@klinkmann.spb.ru

Kiev
tel. +38 044 495 3340
klinkmann@klinkmann.kiev.ua

Riga
tel. +371 6738 1617
klinkmann@klinkmann.lv

Vilnius
tel. +370 5 215 1646
post@klinkmann.lt

Tallinn
tel. +372 668 4500
klinkmann.est@klinkmann.ee

Minsk
tel. +375 17 200 0876
minsk@klinkmann.com