



- Compact**
- Flat design**
- High air through-flow**
- Temperature safety cut-out**
- Clip fixing**

The compact high-performance fan heater prevents formation of condensation in control or switch systems and provides an evenly distributed interior air temperature in enclosures. This fan heater is available without fan (HV 031) as well as with fan (HVL 031).



**Technical Data**

<b>HV 031</b>	Heater without fan (fan mounting kit included)
<b>HVL 031</b>	Heater with fan
<b>Heating element</b>	high performance cartridge
<b>Temperature safety cut-out</b>	to protect against overheating in case of fan failure
<b>Heater body</b>	die-cast aluminium (glass bead blasted)
<b>Connection</b>	3-pole screw connector 2.5mm <sup>2</sup> , clamping torque 0.8Nm
<b>Connection casing</b>	plastic according to UL94 V-0, black
<b>Mounting</b>	clip for 35mm DIN rail, EN 50022
<b>Fitting position</b>	horizontal
<b>Operating/Storage temperature</b>	-45 to +70°C (-49 to +158°F)
<b>Protection type / Protection class</b>	IP20 / I (earthed)
<b>*Axial fan, ball bearing</b>	airflow see table service life 50,000h at 25°C (77°F)
<b>*Connection (axial fan)</b>	2-pole screw connector 2.5mm <sup>2</sup> (L2/N2)
<b>(*HVL 031 only)</b>	
<b>Approvals</b>	UL File No. E187294 (only 230VAC: VDE)

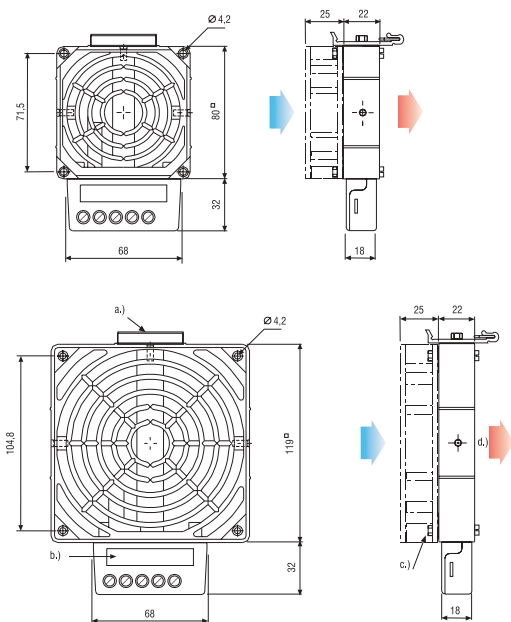

a.) Clip  
b.) Type plate  
c.) Axial fan  
d.) Air direction



**Important!** Heater may only be operated together with fan. Danger of overheating!

Art. No. HV 031 230VAC, 50/60Hz	Art. No. HV 031 120VAC, 50/60Hz	Heating capacity	Dimensions	Weight (approx.)
03100.0-00	03100.9-00	100W	80 x 112 x 22mm	0.40kg
03101.0-00	03101.9-00	150W	80 x 112 x 22mm	0.40kg
03110.0-00	03110.9-00	200W	119 x 151 x 22mm	0.50kg
03111.0-00	03111.9-00	300W	119 x 151 x 22mm	0.50kg
03112.0-00	03112.9-00	400W	119 x 151 x 22mm	0.50kg

Art. No. HVL 031 230VAC, 50/60Hz	Art. No. HVL 031 120VAC, 50/60Hz	Heating capacity	Airflow min., free flow	Dimensions	Weight (approx.)
03102.0-00	03102.9-00	100W	35m <sup>3</sup> /h	80 x 112 x 47mm	0.60kg
03103.0-00	03103.9-00	150W	35m <sup>3</sup> /h	80 x 112 x 47mm	0.60kg
03113.0-00	03113.9-00	200W	108m <sup>3</sup> /h	119 x 151 x 47mm	0.90kg
03114.0-00	03114.9-00	300W	108m <sup>3</sup> /h	119 x 151 x 47mm	0.90kg
03115.0-00	03115.9-00	400W	108m <sup>3</sup> /h	119 x 151 x 47mm	0.90kg

Specifications are subject to change without notice. Suitability of this product for its intended use and any associated risks must be determined by the end customer/buyer in its final application. 24.04.2006